

EMUFO Series

Self- Diagnostic LED Emergency Driver

INSTALLATION MANUAL

!!! IMPORTANT SAFEGUARDS !!!

WHEN USING ELECTRICAL EQUIPMENT, BASIC SAFETY PRECAUTION SHOULD ALWAYS BE FOLLOWED, INCLUDING THE FOLLOWING

READ AND FOLLOW ALL SAFETY INSTRUCTION

- CAUTION** - The emergency driver is only used for emergency back up of LED light load, do not use for other than intended use.
- WARNING** -This **EMUFO** provides more than one power supply output source. To reduce the risk of electrical shock, disconnect both normal and emergency source by turning off the A.C. branch circuit.
- CAUTION** - Servicing of this equipment should be performed by qualified personnel only.
- CAUTION** - Do not attempt to service the battery. A sealed, no-maintenance battery is used that is not field replaceable. Replace the entire unit when necessary.
- CAUTION** - The use of accessory equipment not recommended by the manufacturer may cause an unsafe condition, void warranty, and result in non-compliance with UL specifications.
- IMPORTANT** - The **EMUFO** requires an un-switched AC power source of **100-347VAC, 50/60Hz**. Installer must confirm that fixtures input voltage covered 120VAC before installation. It will supply power under an output voltage of 170VDC in emergency mode for at least 90 minutes.
- CAUTION** - Battery pack should be charge for 24 hours every 6 months during storage.
- IMPORTANT** - Battery in this unit may not be fully charged. After electricity is connected to the unit for at least 24 hours, then normal operation of this unit should take effect.
- IMPORTANT** - The **EMUFO** should be turned off by pressed test switch or Button A once, before maintenance, storage or shipping.
- For use in 0°C minimum, 50°C maximum ambient temperatures. Suitable for use in damp locations and plenum spaces.
- The **EMUFO** should be mounted in locations and at heights where it will not readily be subjected to tampering by unauthorized personnel.
- Do not use this equipment for anything other than its intended use. Equipment only use for LED Lighting emergency backup.
- Do not mount near gas or electric heaters. Do not let power supply cords touch hot surfaces.
- Do not make or leave any other open holes in the wiring enclosure or electrical component enclosure during installation.
- This fixture is for use with grounded, UL Listed, damp location rated, indoor fixture. Not for use in heated air outlets or hazardous locations.
- Make sure all connections are in accordance with the requirements of National Electrical Code & Canadian Electrical Code or any other local regulations.
- This emergency backup is intended to be mounted outside a luminaire which is suitable for both factory and field installation.
- Do not use outdoor.

LUMEN OUTPUT DURING EMERGENCY OPERATION

The luminaire rated data and maximum mounting height can be found as follows:

- Determine the fixture efficacy under normal AC operation, based on fixture manufacturer published data in lumens per watt (LM/W).
- Reference DLC QPL (www.designlights.org) and Energy Star QPL (www.energystar.gov) for rated data on fixture efficacy. If fixture is not found on DLC or Energy Star Qualified Product List, contact fixture manufacturer.
- Multiply **fixture LM/W** by **rated output power of emergency pack** Example ' model EMUFO-25170' is 25 W x 100 LM/W = 2500 Lumens.

PRODUCT COMPONENTS

NOTE: The IP65 version of EMUFO is an optional, please order necessarily waterproof components separately before ordering. (see datasheet)

NOTE: Before wiring, make sure safety rope is securely locked.

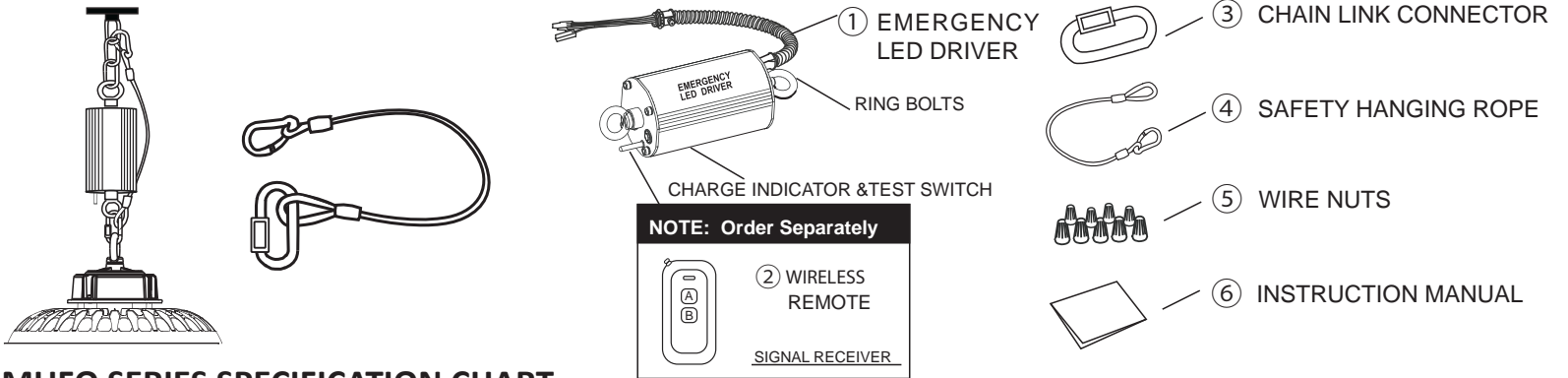

EMUFO SERIES SPECIFICATION CHART

Models	Output Power	Output Voltage
EMUFO-25170-YY	25Watts (Constant)	 HIGH VOLTAGE OUTPUT 170V DC
EMUFO-40170-YY	40Watts (Constant)	

CAUTION— See the **EMUFO Model Specification Chart** for output specifications of the unit being installed.
 For unit of EMUFO-25170-YY better for LED lamp less than 150W.
 For unit of EMUFO-40170-YY for LED lamp less than 320W.

SELF-DIAGNOSTIC (MAINTENANCE)

The integrated Self- Diagnostic circuitry will automatically conduct 1 monthly 30-second and annual 90-minute tests to verify proper emergency capability per Life Safety Code requirements. NFPA 101, Life Safety Code Outlines the following schedule:

- Monthly**- During AC mode, the system conducts a (30)seconds self-discharge test of the emergency led driver every 30 days. And automatically restore to normal charging after (30)seconds dis-charged.
- Annually**- During AC mode, the system conducts a (90)minutes self-discharge test of the emergency led driver every 365 days. And automatically restore to normal charging after fully dis-charged.
- “Written Records of the Testing should be kept by the owner for inspection by the authority having jurisdiction.”** If the charging indicator is flashing rapidly or off, contact manufacturer.

SAVE THESE INSTRUCTIONS



THIS PRODUCT CONTAINS A RECHARGEABLE LITHIUM-ION BATTERY. THE BATTERY MUST BE RECYCLED OR DISPOSED OF PROPERLY TO PREVENT FIRE.

WIRING DIAGRAM

CAUTION  **Note: the EM UFO emergency driver is compatible with 0-10V dim LED Fixtures only.**
Risk of Electric Shock

FIG A. without dimmer and sensor

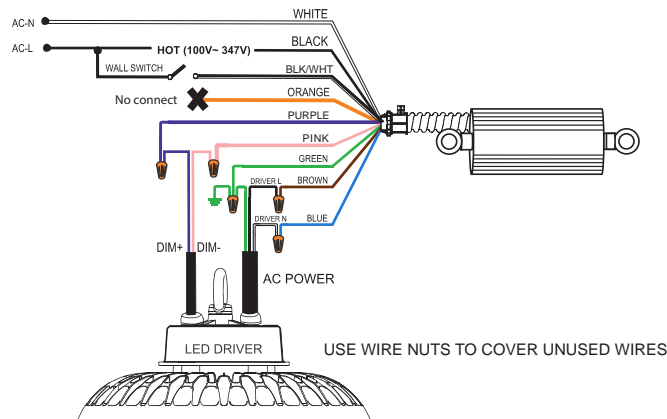

FIG B. with dimmer

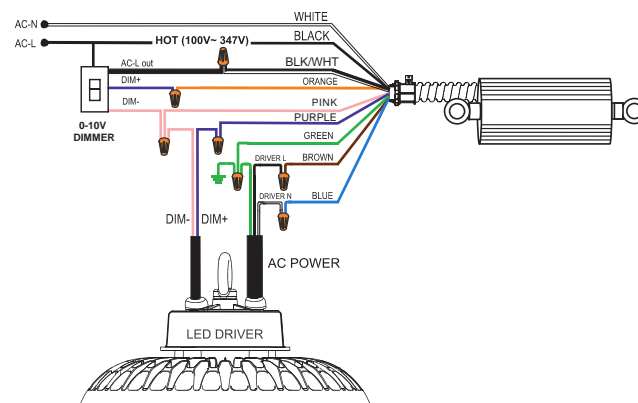

FIG C. with DC sensor

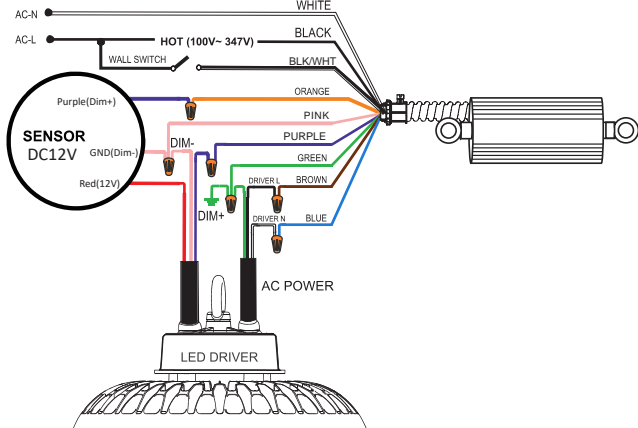
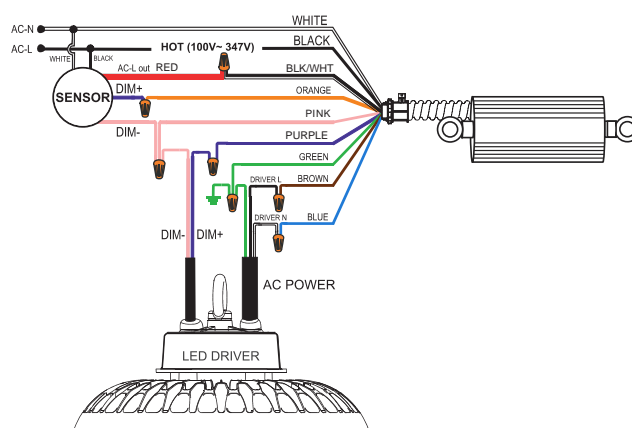

FIG D. with AC sensor



Caution: Before Installation, Make Certain The A.C. Power is Off !

STEP 1: ASSEMBLING NOTICE

- > The Maximum weight of lighting fixture should be less than 20kg.
- > Before wiring, make sure safety rope is securely locked and make sure all the screws are tight.

STEP 2: INSTALLING

- > Turn off the AC power before installing.
- > Assembling the EM backup with the Safety Rope with the chain link connector.
- > The IP65 version of EMUFO is an optional for this series, please using waterproof flexible conduit, connector and J-box to install it if it is necessary.

STEP 3: WIRING

- > Select the appropriate wiring diagram to connect the emergency driver to the AC driver. For other diagrams, consult the manufacturer.
- > The voltage input to the dimmable wires (DIM+, DIM-) of emergency LED driver must less than 20Vdc.
- > Using wire nuts to cover un-used wires and make sure all connections are in accordance with the NEC and any local regulations.

STEP 4: TESTING

- > After wiring is complete, apply A.C. power. Check if the indicator light lights or not, which will indicate the battery's charging situation.
- > The battery in this unit may not be fully charged. A short-term discharge test may be conducted after the EMUFO has been charging for 1 hour. Charge for 24 hours before conducting a long-term discharge test.

OPERATION (INDICATOR STATUS)

Mode	Test Switch Operation	Wireless Remote Operation	Indicator Status	Comment & Solutions
AC MODE (1)	NO Pressed	NO Pressed	ON(no flashing)	Battery is charging
AC MODE (2)	Pressed once	Pressed Button A once	2s ON and 2s OFF (slow flashing)	Battery is conducting a 30s short-term emergency test
AC MODE (3)	Pressed twice (2s) in sequence	Pressed Button B once	2s ON and 2s OFF (slow flashing)	Battery is conducting a long-term emergency test until battery is fully discharged
EMERGENCY MODE (1)	NO Pressed	NO Pressed	2s ON and 2s OFF (slow flashing)	Battery is automatically conducting a emergency until battery is fully discharged
EMERGENCY MODE (2)	Pressed once	Pressed Button A once	OFF	Battery is turned off
PROBLEM	When indicator flashes (0.2s) ON and (0.2s) OFF fast or goes off, the emergency backup pack is abnormal. Contact the manufacturer.			

WARNING
Risk of Electric Shock



Note: Please pressed test switch or wireless remote button A of the EMUFO (in once) and make certain the battery is turned off, before installation, maintenance, storage or shipping.