

DATE:	PROJECT:
TYPE:	NOTES:
CATALOG #:	

## ASFM | ASTORIA FLUSH MOUNT

### 3 CCT COLOR PREFERENCE®

#### KEY FEATURES

- Luminaire uses ETI's patented Color Preference® with 3 Selectable CCTs Standard (3000K, 4000K, 5000K)
- 80+ CRI
- TRIAC Dimming (120V)

#### SPECIFICATIONS

##### Construction

- Steel housing with Black Finish

##### Optics

- High impact, polymer diffuser lens for zero pixelation and overall visual comfort
- Uniform, even light distribution
- Backlit technology

##### Installation

- Field select CCT using integral switch behind the lens prior to installation. Ships at lowest Color Temperature.
- Mounting Kit Included
- Keyhole for direct J-box install

##### Electrical

- > 50,000 hour LEDs at L70 for reduced maintenance
- Operates at 120V, 60Hz
- TRIAC dimming, down to 10%\* (120V)
- Operating Temperature: -4°F to 104°F (-20°C to 40°C)
- ETI's patented selectable CCT COLOR PREFERENCE® allows for easy field-adjustable color temperature selection with switch located inside fixture.

\* Always consult dimmer manufacturer for proper use, installation and compatibility (some dimmers may require a neutral in the wall box).

##### Warranty

5-Year Standard Warranty. See terms at: [ETISSL.com/warranty/](https://www.etissl.com/warranty/)



KEY DATA	
LUMEN RANGE	2043 – 2327
WATTAGE RANGE	30.7 – 31.3
EFFICACY RANGE (LPW)	67 – 74
REPORTED LIFE (HOURS)	L70 / > 50,000

#### Certifications & Test Data

- All luminaires are ETL Listed (US, C) for Damp Location
- Adheres to LM63, LM79, LM80 and TM21 industry standards for photometric, lumen maintenance and lifetime calculations
- Suitable for use in closets when installed in accordance to NEC Section 410.16 (A)(1) and 410.16 (C)(1)

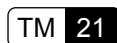

CATALOG LOGIC

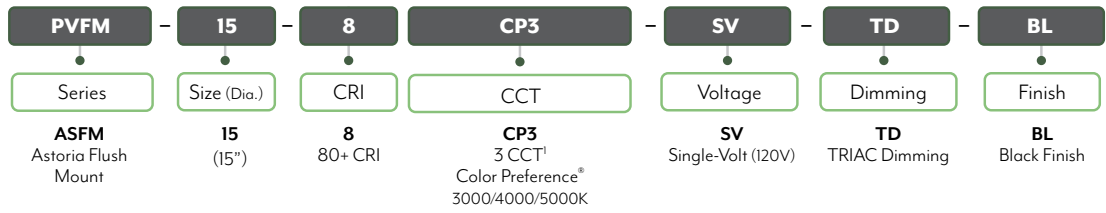

Notes:

- Ships at 3000K CCT. Installing contractor responsible for ensuring desired CCT selected during installation.

STOCK ORDERING INFORMATION

CATALOG PART NUMBER	ORDER NUMBER	DESCRIPTION	CASE QTY	CRI	CCT	WATTS (NOM.)	LUMEN PKG. <sup>1</sup>	DELIVERED LUMENS	LPW	VOLTAGE	DIM
ASFM-15-8CP3-SV-TD-BL	C01174401A	15" Astoria Flush Mount	2	80+	3000K	30	2000	2043	67	120V	TRIAC
					4000K	30	2000	2327	74		
					5000K	30	2000	2146	69		

Notes: 1. For more delivered lumens and test data see pages 3, or visit ETISSL.com

DIMENSIONS / DETAILS

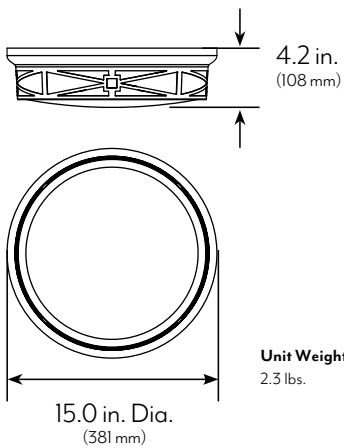

Easy access to color temperature select switch underneath the twist-off lens

MOUNTING

Mounting screws and wire connectors included.



**PERFORMANCE / Data**

**Lumen Maintenance**

Ambient Temp.	TM-21 Lumen Maintenance (54,000 hours)
25° C (77° F)	> 89.49%
Ambient Temp.	TM-21 Theoretical L70 (hours)
25° C (77° F)	> 50,000

**Load Information**

<b>Power Factor</b>	> 0.90
<b>THD</b>	< 20%
<b>Frequency</b>	60 Hz
<b>Low Temp Start / Max Temp</b>	-4°F to 104°F (-20°C to 40°C)

**DIMMER COMPATIBILITY LIST**

DIMMER BRAND	DIMMER MODEL
<b>TRIAC DIMMERS</b>	
LUTRON	SCL-153P
LUTRON	NTCL-250
LUTRON	GT-150
LEVITON	DSL06-1LZ
LEVITON	TSL06
LEVITON	RDL06
COOPER	9573
COOPER	DLC03P
COOPER	SUT7
COOPER	TAL06P2

\* Always consult dimmer manufacturer for proper use, installation and compatibility (some dimmers may require a neutral in the wall box).

**PHOTOMETRIC SAMPLE**



**Luminaire Data:**

CCT & CRI	<b>4000K, 80+ CRI</b>
DELIVERED LUMENS	<b>2327</b>
WATTAGE	<b>31.3W</b>
EFFICACY	<b>74</b>
SPACING	<b>0° = 1.43 90° = 1.38</b>

Photometric values based on tests performed in compliance with LM-63 & LM-79

**Candela Plot**

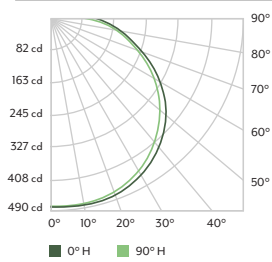

**135°**  
Beam Angle